



Telescopic handle

DIE SET TABLE P16HPS

Die #	Crimp.range	D	L
10	10.0-12.0	10	55
12	12.0-14.0	12	55
14	14.0-16.0	14	55
16	16.0-19.0	16	55
19	19.0-23.0	19	55
23	23.0-27.0	23	55
27	27.0-31.0	27	65
31	31.0-39.0	31	65

3 Times faster than previous model

Benefit:

- 1" Bent Fitting
- No electricity required
- Enerpac Hand Pump
- 8 Die Sets

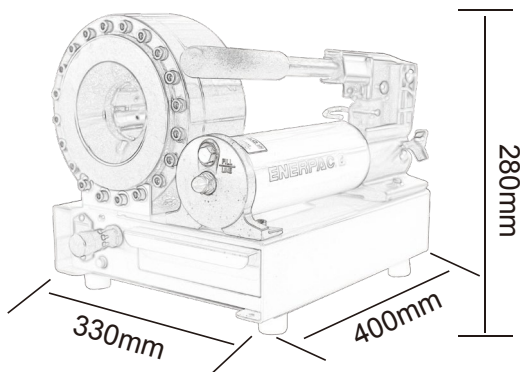

Main Specification	P16HPS
Max Hydraulic Hose	1"3 wire
Crimping Range mm	4-45
Die Type	P16
Master Die Length mm	80
Max Opening mm	+20
Hand Pump	Enerpac two stage pump 700 bar
Speed of Crimping	3 time faster compared to P16HP
Crimping Force KN	1000
Control	Micro Dail
L*W*H mm	330*400*280
Weight KG	26